

primus

Industrial Tumble Dryers T 24, T 35



FEATURES

- Standard stainless steel drum with large diameter
- Easy Control microprocessor
- Easy to use microprocessor
- Radial airflow with PowerDry®
 - maximal heat transfer
 - low energy consumption
 - short drying time
- Large door opening for easy loading and unloading

OPTIONS

- Coin operated version
- Reversing drum
- Full Control programmer
- Residual moisture control Sensodry®:
 - safe drying of delicate linen
 - humidity detection in °C
 - ideal in combination with SoftWash®
 - ideal for dry cleaners, fire depts
 - available on Easy and Full Control
- LPMS networking software
- Stainless steel front

 **senso.dry®**

 **POWERDRY®**

TYPE		T 24	T 35
CAPACITY			
Nominal	kg (lb)	24 (53)	35 (77)
DRUM DIMENSIONS			
Drum volume	l	530	680
Drum \emptyset x D	mm	930x780	930x1000
AIRFLOW	m ³ /h	1200	1500
DRYING AVERAGE	l/min.	0,384	0,560
MOTORS			
Fan	kW	0,75	0,75
Drive	kW	0,37	0,37
ENERGY DATA			
GAS HEATING			
Energy	kW kBTU/h	39 119,4	50 163,8
Electrical connection		208V-240V/1/50Hz (380V-415V/3/50Hz)	
Gas connection	NPT	3/4"	
STEAM HEATING			
Steam high pressure	Bar	3-6/7-10	3-6/7-10
Energy	kW kBTU/h	36/39 157	46,6/54,5 191
Electrical connection		208V-240V/1/50Hz (380V-415V/3/50Hz)	
Steam connection	NPT	3/4"	
ELECTRICAL HEATING			
Energy	kW	30/36	36/48
Electrical connection		380V-415V/3/50Hz	
PROGRAMMER			
Easy control - antivandal		+	+
Full control		Standard	Standard
EXHAUST	mm	200	200
DIMENSIONS			
HxWxD unpacked	mm	1975x965x1270	1975x965x1490
HxWxD packed	mm	2075x1040x1320	2075x1040x1540
WEIGHT			
Net	kg	276	305
Gross	kg	301	330
+ = available			

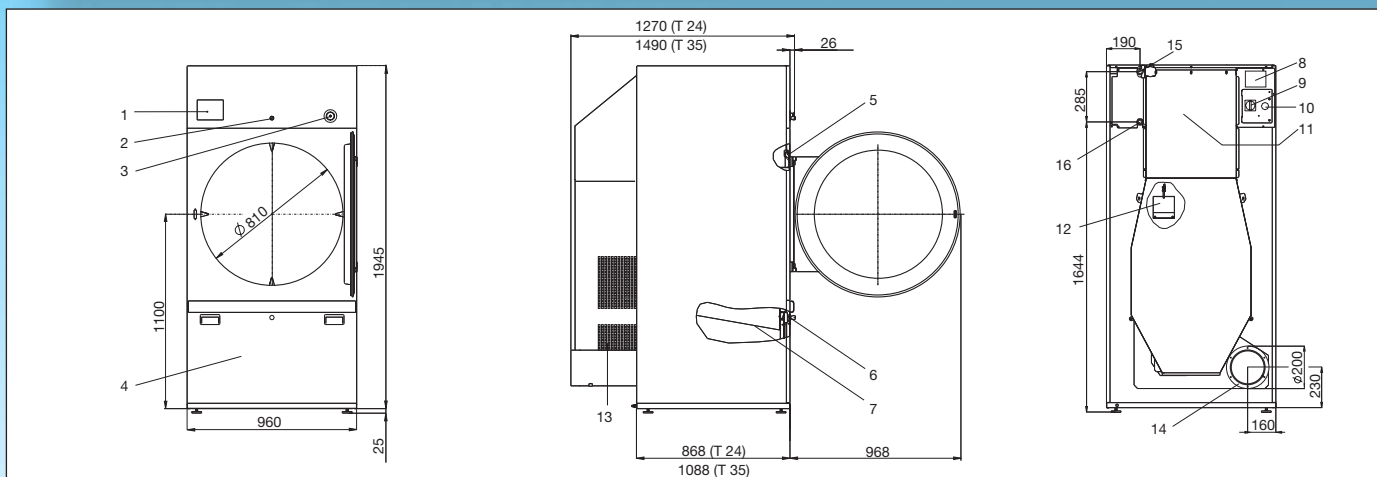

- | | |
|------------------------------|-----------------------|
| 1. Programmer | 9. Main switch |
| 2. Lock of the control panel | 10. Main power supply |
| 3. Emergency stop button | 11. Heating chamber |
| 4. Lint screen cover | 12. Airflow switch |
| 5. Door lock microswitch | 13. Suction |
| 6. Lint cover microswitch | 14. Exhaust piping |
| 7. Lint screen | 15. Steam supply |
| 8. Name plate | 16. Condense drain |

The company Primus preserves the right to change the machines and the specification in this leaflet at any time, without prior notice. Details and photographs are only for information and never binding.

www.primuslaundry.com

primus



Quality **without**
compromise